



RECORDS OF REVISION

DOC. FIRST ISSUE

MAY.25, 2009

DATE	REVISED PAGE NO.	SUMMARY																																																																																																												
JUN.05, 2009	2	<p>3.2 ENVIRONMENTAL ABSOLUTE MAXIMUM RATINGS</p> <table border="1"> <thead> <tr> <th rowspan="2">I T E M</th> <th colspan="2">OPERATING</th> <th colspan="2">STORAGE</th> <th rowspan="2">REMARK</th> </tr> <tr> <th>MIN.</th> <th>MAX.</th> <th>MIN.</th> <th>MAX.</th> </tr> </thead> <tbody> <tr> <td>AMBIENT TEMPERATURE</td> <td>-10°C</td> <td>60°C</td> <td>-20°C</td> <td>70°C</td> <td>NOTE (1), (3)</td> </tr> </tbody> </table> <p style="text-align: center;">↓</p> <table border="1"> <thead> <tr> <th rowspan="2">I T E M</th> <th colspan="2">OPERATING</th> <th colspan="2">STORAGE</th> <th rowspan="2">REMARK</th> </tr> <tr> <th>MIN.</th> <th>MAX.</th> <th>MIN.</th> <th>MAX.</th> </tr> </thead> <tbody> <tr> <td>AMBIENT TEMPERATURE</td> <td>-20°C</td> <td>70°C</td> <td>-30°C</td> <td>80°C</td> <td>NOTE (1), (3)</td> </tr> </tbody> </table> <p>NOTE (3) : Ta AT -20°C:WILL BE &lt; 48HR.→ -30°C:WILL BE &lt; 48HR. 70°C:WILL BE &lt; 168HR.→ 80°C:WILL BE &lt; 168HR.</p>	I T E M	OPERATING		STORAGE		REMARK	MIN.	MAX.	MIN.	MAX.	AMBIENT TEMPERATURE	-10°C	60°C	-20°C	70°C	NOTE (1), (3)	I T E M	OPERATING		STORAGE		REMARK	MIN.	MAX.	MIN.	MAX.	AMBIENT TEMPERATURE	-20°C	70°C	-30°C	80°C	NOTE (1), (3)																																																																												
I T E M	OPERATING			STORAGE		REMARK																																																																																																								
	MIN.	MAX.	MIN.	MAX.																																																																																																										
AMBIENT TEMPERATURE	-10°C	60°C	-20°C	70°C	NOTE (1), (3)																																																																																																									
I T E M	OPERATING		STORAGE		REMARK																																																																																																									
	MIN.	MAX.	MIN.	MAX.																																																																																																										
AMBIENT TEMPERATURE	-20°C	70°C	-30°C	80°C	NOTE (1), (3)																																																																																																									
	3	<p>4.1 ELECTRICAL CHARACTERISTICS OF LCM</p> <table border="1"> <thead> <tr> <th>PARAMETER</th> <th>SYMBOL</th> <th>CONDITION</th> <th>MIN.</th> <th>TYP.</th> <th>MAX.</th> <th>UNIT</th> </tr> </thead> <tbody> <tr> <td rowspan="3">RECOMMENDED LCD DRIVING VOLTAGE</td> <td rowspan="3">VEE-VSS</td> <td>Ta=-10°C</td> <td>(23.3)</td> <td>(23.6)</td> <td>(23.9)</td> <td rowspan="3">V</td> </tr> <tr> <td>Ta=25°C</td> <td>(19.7)</td> <td>(21.9)</td> <td>(24.1)</td> </tr> <tr> <td>Ta=60°C</td> <td>(21.7)</td> <td>(22.0)</td> <td>(22.3)</td> </tr> </tbody> </table> <p style="text-align: center;">↓</p> <table border="1"> <thead> <tr> <th>PARAMETER</th> <th>SYMBOL</th> <th>CONDITION</th> <th>MIN.</th> <th>TYP.</th> <th>MAX.</th> <th>UNIT</th> </tr> </thead> <tbody> <tr> <td rowspan="3">RECOMMENDED LCD DRIVING VOLTAGE</td> <td rowspan="3">VEE-VSS</td> <td>Ta=-20°C</td> <td>(23.3)</td> <td>(23.6)</td> <td>(23.9)</td> <td rowspan="3">V</td> </tr> <tr> <td>Ta=25°C</td> <td>(19.7)</td> <td>(21.9)</td> <td>(24.1)</td> </tr> <tr> <td>Ta=70°C</td> <td>(21.7)</td> <td>(22.0)</td> <td>(22.3)</td> </tr> </tbody> </table> <p>DELETE: LED BACKLIGHT FORWARD VOLTAGE</p> <p>4.2.1 ELECTRICAL / OPTICAL CHARACTERISTICS AT Ta=25°C</p> <table border="1"> <thead> <tr> <th>PARAMETER</th> <th>SYMBOL</th> <th>MIN.</th> <th>TYP.</th> <th>MAX.</th> <th>UNIT</th> <th>REMARK</th> </tr> </thead> <tbody> <tr> <td>FORWARD VOLTAGE</td> <td>V<sub>F</sub></td> <td>4.9</td> <td>5.0</td> <td>5.1</td> <td>V</td> <td>IF=120mA</td> </tr> <tr> <td>LED LIFE TIME</td> <td>L</td> <td>30K</td> <td>50K</td> <td>—</td> <td>HR</td> <td>Ta=25°</td> </tr> </tbody> </table> <p style="text-align: center;">↓</p> <table border="1"> <thead> <tr> <th>PARAMETER</th> <th>SYMBOL</th> <th>MIN.</th> <th>TYP.</th> <th>MAX.</th> <th>UNIT</th> <th>REMARK</th> </tr> </thead> <tbody> <tr> <td>FORWARD VOLTAGE</td> <td>V<sub>F</sub></td> <td>—</td> <td>5.0</td> <td>—</td> <td>V</td> <td>IF=120mA</td> </tr> <tr> <td>LED LIFE TIME</td> <td>L</td> <td>30K</td> <td>40K</td> <td>—</td> <td>HR</td> <td>Ta=25°</td> </tr> </tbody> </table>	PARAMETER	SYMBOL	CONDITION	MIN.	TYP.	MAX.	UNIT	RECOMMENDED LCD DRIVING VOLTAGE	VEE-VSS	Ta=-10°C	(23.3)	(23.6)	(23.9)	V	Ta=25°C	(19.7)	(21.9)	(24.1)	Ta=60°C	(21.7)	(22.0)	(22.3)	PARAMETER	SYMBOL	CONDITION	MIN.	TYP.	MAX.	UNIT	RECOMMENDED LCD DRIVING VOLTAGE	VEE-VSS	Ta=-20°C	(23.3)	(23.6)	(23.9)	V	Ta=25°C	(19.7)	(21.9)	(24.1)	Ta=70°C	(21.7)	(22.0)	(22.3)	PARAMETER	SYMBOL	MIN.	TYP.	MAX.	UNIT	REMARK	FORWARD VOLTAGE	V <sub>F</sub>	4.9	5.0	5.1	V	IF=120mA	LED LIFE TIME	L	30K	50K	—	HR	Ta=25°	PARAMETER	SYMBOL	MIN.	TYP.	MAX.	UNIT	REMARK	FORWARD VOLTAGE	V <sub>F</sub>	—	5.0	—	V	IF=120mA	LED LIFE TIME	L	30K	40K	—	HR	Ta=25°																						
PARAMETER	SYMBOL	CONDITION	MIN.	TYP.	MAX.	UNIT																																																																																																								
RECOMMENDED LCD DRIVING VOLTAGE	VEE-VSS	Ta=-10°C	(23.3)	(23.6)	(23.9)	V																																																																																																								
		Ta=25°C	(19.7)	(21.9)	(24.1)																																																																																																									
		Ta=60°C	(21.7)	(22.0)	(22.3)																																																																																																									
PARAMETER	SYMBOL	CONDITION	MIN.	TYP.	MAX.	UNIT																																																																																																								
RECOMMENDED LCD DRIVING VOLTAGE	VEE-VSS	Ta=-20°C	(23.3)	(23.6)	(23.9)	V																																																																																																								
		Ta=25°C	(19.7)	(21.9)	(24.1)																																																																																																									
		Ta=70°C	(21.7)	(22.0)	(22.3)																																																																																																									
PARAMETER	SYMBOL	MIN.	TYP.	MAX.	UNIT	REMARK																																																																																																								
FORWARD VOLTAGE	V <sub>F</sub>	4.9	5.0	5.1	V	IF=120mA																																																																																																								
LED LIFE TIME	L	30K	50K	—	HR	Ta=25°																																																																																																								
PARAMETER	SYMBOL	MIN.	TYP.	MAX.	UNIT	REMARK																																																																																																								
FORWARD VOLTAGE	V <sub>F</sub>	—	5.0	—	V	IF=120mA																																																																																																								
LED LIFE TIME	L	30K	40K	—	HR	Ta=25°																																																																																																								
	6	<p>6. OPTICAL CHARACTERISTICS</p> <table border="1"> <thead> <tr> <th>I T E M</th> <th>SYMBOL</th> <th>CONDITION</th> <th>MIN.</th> <th>TYP.</th> <th>MAX.</th> <th>UNIT</th> <th>NOTE</th> </tr> </thead> <tbody> <tr> <td rowspan="6">RESPONSE TIME</td> <td rowspan="3">tr (rise)</td> <td>Ta = -10°C</td> <td>—</td> <td>(1900)</td> <td>(2470)</td> <td rowspan="3">ms</td> <td rowspan="6">(1)</td> </tr> <tr> <td>Ta = 25°C</td> <td>—</td> <td>(320)</td> <td>(420)</td> </tr> <tr> <td>Ta = 60°C</td> <td>—</td> <td>(90)</td> <td>(120)</td> </tr> <tr> <td rowspan="3">tf (fall)</td> <td>Ta = -10°C</td> <td>—</td> <td>(1100)</td> <td>(1430)</td> <td rowspan="3">ms</td> </tr> <tr> <td>Ta = 25°C</td> <td>—</td> <td>(185)</td> <td>(240)</td> </tr> <tr> <td>Ta = 60°C</td> <td>—</td> <td>(90)</td> <td>(120)</td> </tr> <tr> <td>THE BRIGHTNESS OF MODULE</td> <td>L</td> <td>ILED=120mA</td> <td>100</td> <td>150</td> <td>—</td> <td>cd / m<sup>2</sup></td> <td>(2), (3)</td> </tr> <tr> <td>THE UNIFORMITY OF MODULE</td> <td>—</td> <td>—</td> <td>(70)</td> <td>—</td> <td>—</td> <td>%</td> <td>(2), (3)</td> </tr> </tbody> </table> <p style="text-align: center;">↓</p> <table border="1"> <thead> <tr> <th>I T E M</th> <th>SYMBOL</th> <th>CONDITION</th> <th>MIN.</th> <th>TYP.</th> <th>MAX.</th> <th>UNIT</th> <th>NOTE</th> </tr> </thead> <tbody> <tr> <td rowspan="6">RESPONSE TIME</td> <td rowspan="3">tr (rise)</td> <td>Ta = -20°C</td> <td>—</td> <td>(1900)</td> <td>(2470)</td> <td rowspan="3">ms</td> <td rowspan="6">(1)</td> </tr> <tr> <td>Ta = 25°C</td> <td>—</td> <td>(320)</td> <td>(420)</td> </tr> <tr> <td>Ta = 70°C</td> <td>—</td> <td>(90)</td> <td>(120)</td> </tr> <tr> <td rowspan="3">tf (fall)</td> <td>Ta = -20°C</td> <td>—</td> <td>(1100)</td> <td>(1430)</td> <td rowspan="3">ms</td> </tr> <tr> <td>Ta = 25°C</td> <td>—</td> <td>(185)</td> <td>(240)</td> </tr> <tr> <td>Ta = 70°C</td> <td>—</td> <td>(90)</td> <td>(120)</td> </tr> <tr> <td>THE BRIGHTNESS OF MODULE</td> <td>L</td> <td>VLED-VLSS=5.0V</td> <td>100</td> <td>150</td> <td>—</td> <td>cd / m<sup>2</sup></td> <td>(2), (3)</td> </tr> <tr> <td>THE UNIFORMITY OF MODULE</td> <td>—</td> <td>—</td> <td>(70)</td> <td>—</td> <td>—</td> <td>%</td> <td>(2), (3)</td> </tr> </tbody> </table>	I T E M	SYMBOL	CONDITION	MIN.	TYP.	MAX.	UNIT	NOTE	RESPONSE TIME	tr (rise)	Ta = -10°C	—	(1900)	(2470)	ms	(1)	Ta = 25°C	—	(320)	(420)	Ta = 60°C	—	(90)	(120)	tf (fall)	Ta = -10°C	—	(1100)	(1430)	ms	Ta = 25°C	—	(185)	(240)	Ta = 60°C	—	(90)	(120)	THE BRIGHTNESS OF MODULE	L	ILED=120mA	100	150	—	cd / m <sup>2</sup>	(2), (3)	THE UNIFORMITY OF MODULE	—	—	(70)	—	—	%	(2), (3)	I T E M	SYMBOL	CONDITION	MIN.	TYP.	MAX.	UNIT	NOTE	RESPONSE TIME	tr (rise)	Ta = -20°C	—	(1900)	(2470)	ms	(1)	Ta = 25°C	—	(320)	(420)	Ta = 70°C	—	(90)	(120)	tf (fall)	Ta = -20°C	—	(1100)	(1430)	ms	Ta = 25°C	—	(185)	(240)	Ta = 70°C	—	(90)	(120)	THE BRIGHTNESS OF MODULE	L	VLED-VLSS=5.0V	100	150	—	cd / m <sup>2</sup>	(2), (3)	THE UNIFORMITY OF MODULE	—	—	(70)	—	—	%	(2), (3)
I T E M	SYMBOL	CONDITION	MIN.	TYP.	MAX.	UNIT	NOTE																																																																																																							
RESPONSE TIME	tr (rise)	Ta = -10°C	—	(1900)	(2470)	ms	(1)																																																																																																							
		Ta = 25°C	—	(320)	(420)																																																																																																									
		Ta = 60°C	—	(90)	(120)																																																																																																									
	tf (fall)	Ta = -10°C	—	(1100)	(1430)	ms																																																																																																								
		Ta = 25°C	—	(185)	(240)																																																																																																									
		Ta = 60°C	—	(90)	(120)																																																																																																									
THE BRIGHTNESS OF MODULE	L	ILED=120mA	100	150	—	cd / m <sup>2</sup>	(2), (3)																																																																																																							
THE UNIFORMITY OF MODULE	—	—	(70)	—	—	%	(2), (3)																																																																																																							
I T E M	SYMBOL	CONDITION	MIN.	TYP.	MAX.	UNIT	NOTE																																																																																																							
RESPONSE TIME	tr (rise)	Ta = -20°C	—	(1900)	(2470)	ms	(1)																																																																																																							
		Ta = 25°C	—	(320)	(420)																																																																																																									
		Ta = 70°C	—	(90)	(120)																																																																																																									
	tf (fall)	Ta = -20°C	—	(1100)	(1430)	ms																																																																																																								
		Ta = 25°C	—	(185)	(240)																																																																																																									
		Ta = 70°C	—	(90)	(120)																																																																																																									
THE BRIGHTNESS OF MODULE	L	VLED-VLSS=5.0V	100	150	—	cd / m <sup>2</sup>	(2), (3)																																																																																																							
THE UNIFORMITY OF MODULE	—	—	(70)	—	—	%	(2), (3)																																																																																																							
	7	<p>7. OUTLINE DIMENSIONS MARK Δ: MODIFY FFC LENGTH.</p>																																																																																																												
	8	<p>8. BLOCK DIAGRAM</p>																																																																																																												
	11	<p>11.2 POWER SUPPLY FOR LED BACK - LIGHT</p>																																																																																																												
	12	<p>12. GENERAL RELIABILITY ASSURANCE</p> <p>NO.1 : (CONDITIONS) 70±2°C→80±2°C NO.2 : (CONDITIONS) -20±2°C→-30±2°C NO.4 : (CONDITIONS) 60±2°C→70±2°C NO.5 : (CONDITIONS) -10±2°C→-20±2°C</p>																																																																																																												

TABLE OF CONTENTS

NO.	ITEM	PAGE
1.	GENERAL SPECIFICATIONS -----	1
2.	MECHANICAL SPECIFICATIONS -----	1
3.	ABSOLUTE MAXIMUM RATINGS -----	2
4.	ELECTRICAL CHARACTERISTICS -----	3
5.	TIMING CHARACTERISTICS -----	4, 5
6.	OPTICAL CHARACTERISTICS -----	6
7.	OUTLINE DIMENSIONS -----	7
8.	BLOCK DIAGRAM -----	8
9.	DETAIL DRAWING OF DOT MATRIX -----	9
10.	INTERFACE SIGNALS -----	10
11.	POWER SUPPLY -----	11
12.	GENERAL RELIABILITY ASSURANCE -----	12

MODEL NO .	VERSION	PAGE
E W 5 0 9 6 1 B M W	2	1

1. GENERAL SPECIFICATIONS

1.1 GENERAL SPECIFICATIONS  
PLEASE REFER TO:

CUSTOMER ACCEPTANCE STANDARD SPECIFICATIONS:

E U - 0 0 2 B

1.2 THIS INDIVIDUAL SPECIFICATION IS PRIOR TO GENERAL SPECIFICATIONS.

1.3 MATERIAL SAFETY DESCRIPTION

ASSEMBLIES SHALL COMPLY WITH EDT GREEN PRODUCT (GP) REQUIREMENTS, INCLUDING PROHIBITED MATERIALS/COMPONENTS CONTAINING LEAD, MERCURY, CADMIUM, HEXAVALENT CHROMIUM, POLYBROMINATED BIPHENYLS (PBB), POLYBROMINATED DIPHENYL ETHERS (PBDE), POLYCHLORINATED BIPHENYLS (PCB) CATEGORY, POLYCHLORINATED NAPHTHALENE (PCN) CATEGORY, POLYCHLORINATED TERPHENYLS (PCT) CATEGORY, CHLORINATED PARAFFINS (CP) CATEGORY, TRIBUTHYL TIN CATEGORY / TRIPHENYL TIN CATEGORY, ASBESTOS, SPECIFIC AZO COMPOUNDS, FORMALDEHYDE, POLYVINYL CHLORIDE (PVC) AND PVC BLENDS, OTHER BROMINATED ORGANIC COMPOUNDS AND OTHER CHLORINATED ORGANIC COMPOUNDS.

2. MECHANICAL SPECIFICATIONS

- (1) NUMBER OF DOTS ----- 320W \* 240H DOTS
- (2) MODULE SIZE ----- 166W \* 109H \* 7D mm
- (3) EFFECTIVE AREA ----- 120.2W \* 90.8H mm
- (4) ACTIVE AREA ----- 115.19W \* 86.39H mm
- (5) DOT SIZE ----- 0.35W \* 0.35H mm
- (6) DOT PITCH ----- 0.36W \* 0.36H mm
- (7) LCD TYPE ----- STN , BLUE , TRANSMISSIVE  
ANTI-GLARE
- (8) DRIVING METHOD ----- 1 / 240 DUTY MULTIPLEX DRIVE
- (9) VIEWING DIRECTION ----- 6 O'CLOCK
- (10) BACKLIGHT ----- LED , COLOR : WHITE

### 3. ABSOLUTE MAXIMUM RATINGS

#### 3.1 ELECTRICAL ABSOLUTE MAXIMUM RATINGS .

PARAMETER	SYMBOL	MIN.	MAX.	UNIT	REMARK
POWER SUPPLY FOR LOGIC	VDD – VSS	-0.3	+6.0	V	
INPUT VOLTAGE	VI	-0.3	VDD+0.3	V	
STATIC ELECTRICITY	—	—	100	V	NOTE ( 1 )

NOTE ( 1 ) : TEST METHOD AND CONDITIONS :

AFTER CHARGING UP 200 pF CAPACITOR BY STATED VOLTAGE, THE CAPACITOR IS CONNECTED WITH INTERFACE PINS OF THE MODULE.

#### 3.2 ENVIRONMENTAL ABSOLUTE MAXIMUM RATINGS .

I T E M	OPERATING		STORAGE		REMARK
	MIN.	MAX.	MIN.	MAX.	
AMBIENT TEMPERATURE	-20°C	70°C	-30°C	80°C	NOTE ( 1 ) , ( 3 )
HUMIDITY	NOTE ( 2 )		NOTE ( 2 )		WITHOUT CONDENSATION
VIBRATION	—	2.45 m /s <sup>2</sup> ( 0.25 G )	—	19.6 m /s <sup>2</sup> ( 2 G )	10~100 Hz XYZ DIRECTIONS 1 HR. EACH
SHOCK	—	2 9.4 m /s <sup>2</sup> ( 3 G )	—	490.0 m /s <sup>2</sup> ( 5 0 G )	10 m SECONDS XYZ DIRECTIONS 1 TIME EACH
CORROSIVE GAS	NOT ACCEPTABLE		NOT ACCEPTABLE		

NOTE ( 1 ) : BACKGROUND COLOR CHANGES SLIGHTLY DEPENDING ON AMBIENT TEMPERATURE THIS PHENOMENON IS REVERSIBLE.

NOTE ( 2 ) : Ta ≤ 60°C : 90%RH (96HR MAX.)

Ta > 60°C : ABSOLUTE HUMIDITY MUST BE LOWER THAN THE HUMIDITY OF 90%RH AT 60°C(96HR MAX.)

NOTE ( 3 ) : Ta AT -30°C: WILL BE < 48HR.

80°C: WILL BE < 168HR.

4 . ELECTRICAL CHARACTERISTICS

4 . 1 ELECTRICAL CHARACTERISTICS OF LCM

Ta = 25 °C

PARAMETER	SYMBOL	CONDITION	MIN.	TYP.	MAX.	UNIT
POWER SUPPLY VOLTAGE FOR LOGIC	VDD – VSS	—	4.75	5.0	5.25	V
POWER SUPPLY VOLTAGE FOR LCD DRIVE	VEE-VSS	—	+15	—	+30	V
INPUT VOLTAGE	VIH	H LEVEL	0.8*VDD	—	—	V
NOTE ( 1 )	VIL	L LEVEL	—	—	0.2*VDD	V
POWER SUPPLY CURRENT FOR LOGIC	IDD	VDD – VSS= 5.0 V VEE – VSS=(21.9)V	—	(1.2)	(1.8)	mA
POWER SUPPLY CURRENT FOR LCD DRIVE	IEE	VDD – VSS= 5.0 V VEE – VSS=(21.9)V	—	(4.5)	(6.5)	mA
RECOMMENDED LCD DRIVING VOLTAGE	VEE-VSS	Ta=-20°C	(23.3)	(23.6)	(23.9)	V
		Ta=25°C	(19.7)	(21.9)	(24.1)	
		Ta=70°C	(21.7)	(22.0)	(22.3)	
CLOCK OSCILLATION FREQUENCY	f FLM	—	70	75	80	Hz

NOTE ( 1 ) : APPLIED TO TERMINALS FLM, CL1, CL2, D0~D3, DISPOFF .

4.2 LED BACK-LIGHT UNIT

4.2.1 ELECTRICAL / OPTICAL CHARACTERISTICS AT Ta=25°C

PARAMETER	SYMBOL	MIN.	TYP.	MAX.	UNIT	REMARK
AVERAGE LUMINOUS INTENSITUY	Iv	(700)	(1000)	—	cd/m <sup>2</sup>	IF=120mA/BACK LIGHT
FORWARD VOLTAGE	V <sub>F</sub>	—	5.0	—	V	IF=120mA
LED LIFE TIME	L	30K	40K	—	HR	Ta=25°

4.2.2 ABSOLUTE MAXIMUM RATINGS AT Ta=25°C

PARAMETER	SYMBOL	SPECIFICATION	UNIT	REMARK
POWER DISSIPATION	PD	(918)	mW	( 1 )
FORWARD CURRENT	IF	(180)	mA	( 2 )
REVERSE VOLTAGE	VR	(5)	V	

NOTE ( 1 ) : INTERNAL CIRCUIT DIAGRAM OF BACKLIGHT

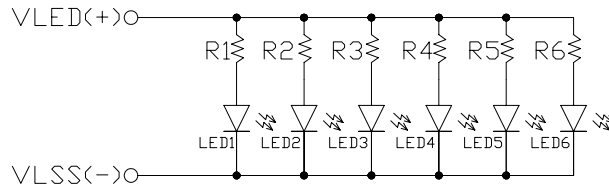

NOTE ( 2 ) : AMBIENT TEMP. VS. ALLOWABLE FORWARD CURRENT (PER LED)

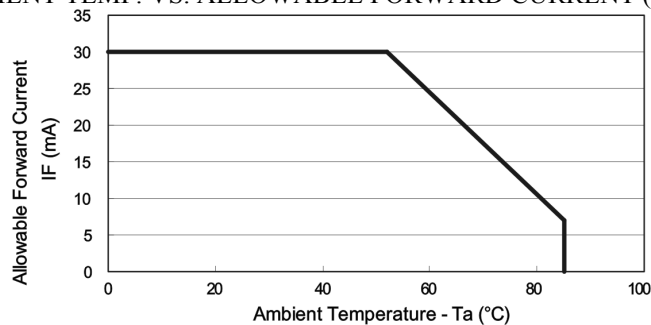

5. TIMING CHARACTERISTICS  
5.1 INTERFACE TIMING

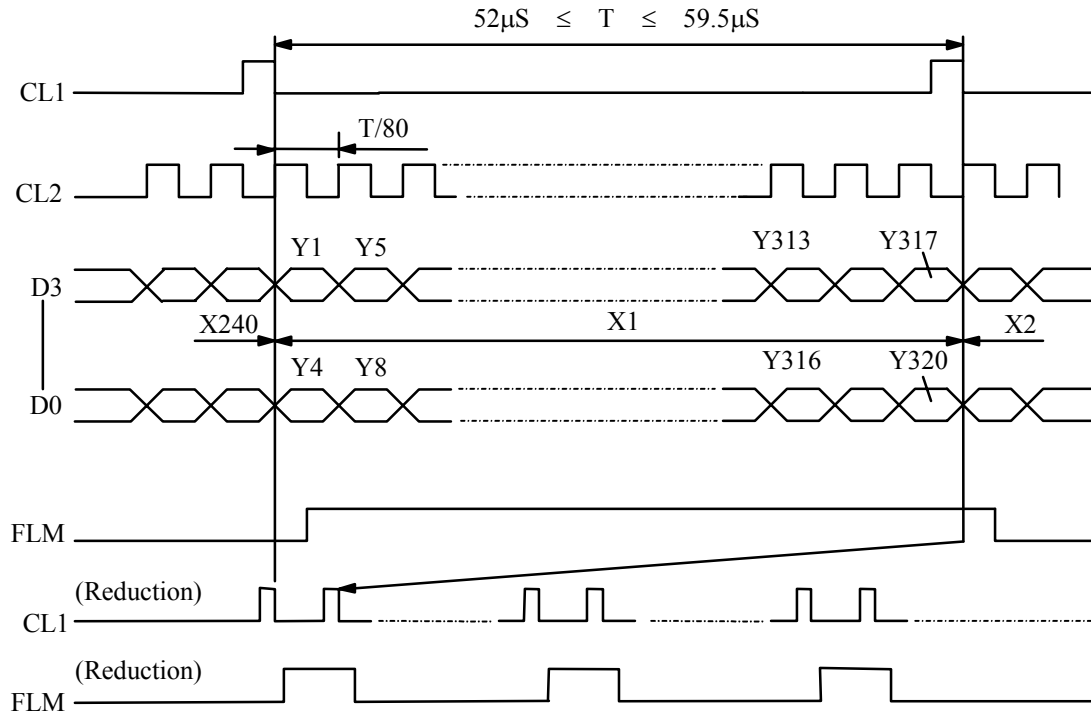

5.2 SWITCHING CHARACTERISTICS

PARAMETER	SYMBOL	MIN.	TYP.	MAX.	UNIT
CL1 PULSE WIDTH	tw1	30	—	—	ns
CL2 PULSE WIDTH	tw	51	—	—	ns
RISE,FALL TIME	tr,tf	—	—	50	ns
DATA SETUP TIME	tDSU	30	—	—	ns
DATA HOLD TIME	tDHD	40	—	—	ns
CL1 SETUP TIME	tLSU	51	—	—	ns
CL1 TO CL2 TIME	tLC	51	—	—	ns
FLM SETUP TIME	tsetup	30	—	—	ns
FLM HOLD TIME	thold	50	—	—	ns

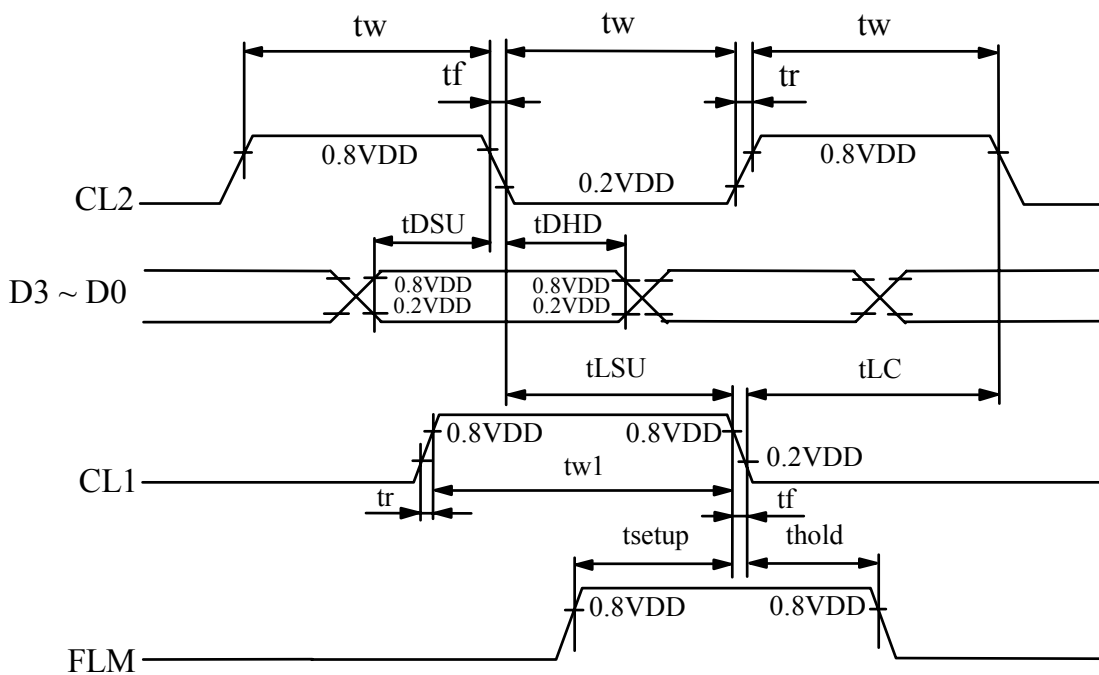



6. OPTICAL CHARACTERISTICS

Ta = 25 °C

I T E M	SYMBOL	CONDITION		MIN.	TYP.	MAX.	UNIT	NOTE
VIEWING ANGLE	$\theta_{y+}$	$K \geq 1.5$	$\theta_x = 0^\circ$	(18)	(25)	—	deg.	(1)
	$\theta_{y-}$			(30)	(37)	—		
	$\theta_{x+}$		$\theta_y = 0^\circ$	(33)	(40)	—		
	$\theta_{x-}$			(33)	(40)	—		
CONTRAST RATIO	K	$\theta_y = 0^\circ$ $\theta_x = 0^\circ$	3	3.5	—	—	(1)	
RESPONSE TIME	tr ( rise )	$\theta_y = 0^\circ$ $\theta_x = 0^\circ$	Ta = -20°C	—	(1900)	(2470)	ms	(1)
			Ta = 25°C	—	(320)	(420)		
			Ta = 70°C	—	(90)	(120)		
	tf ( fall )		Ta = -20°C	—	(1100)	(1430)		
			Ta = 25°C	—	(185)	(240)		
			Ta = 70°C	—	(90)	(120)		
THE BRIGHTNESS OF MODULE	L	VLED-VLSS=5.0V	100	150	—	cd / m <sup>2</sup>	(2), (3)	
THE UNIFORMITY OF MODULE	—		(70)	—	—	%	(2), (3)	

NOTE (1) : PLEASE REFER TO :  
CUSTOMER ACCEPTANCE STANDARD SPECIFICATIONS. (EU – 002B)

NOTE (2) : MEASUREMENT OF THE FOLLOWING 9 PLACES ON THE DISPLAY.  
DEFINITION OF THE BRIGHTNESS TOLERANCE.

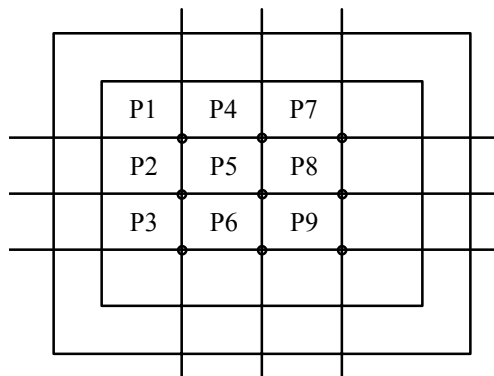

NOTE (3) : BRIGHTNESS UNIFORMITY IS DEFINED AS FOLLOWING

$$\sum_X = \left[ 1 - \frac{\text{MAXIMUM BRIGHTNESS} - \text{MINIMUM BRIGHTNESS}}{\text{AVERAGE BRIGHTNESS}} \right] \times 100\%$$



8. BLOCK DIAGRAM

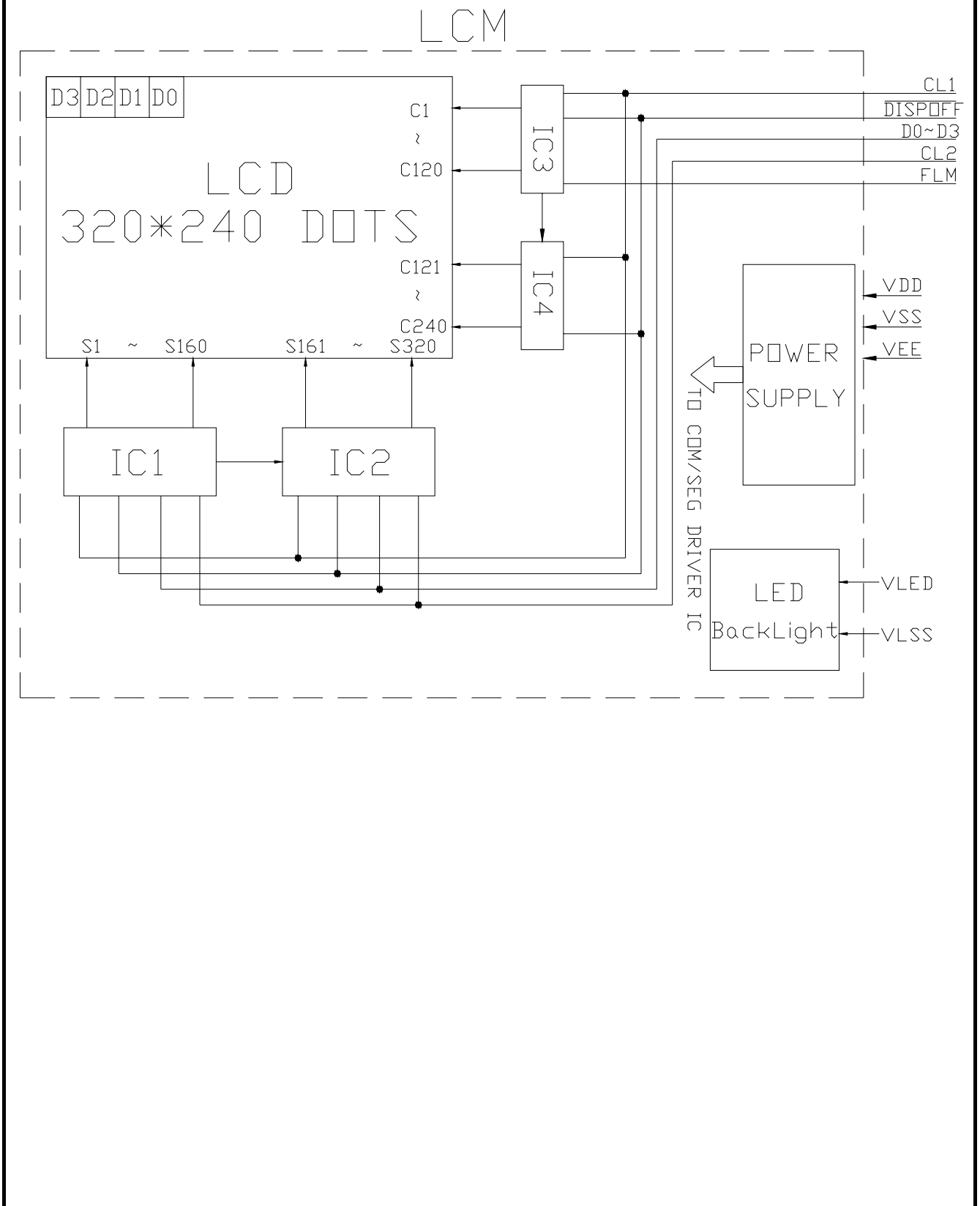

9. DETAIL DRAWING OF DOT MATRIX

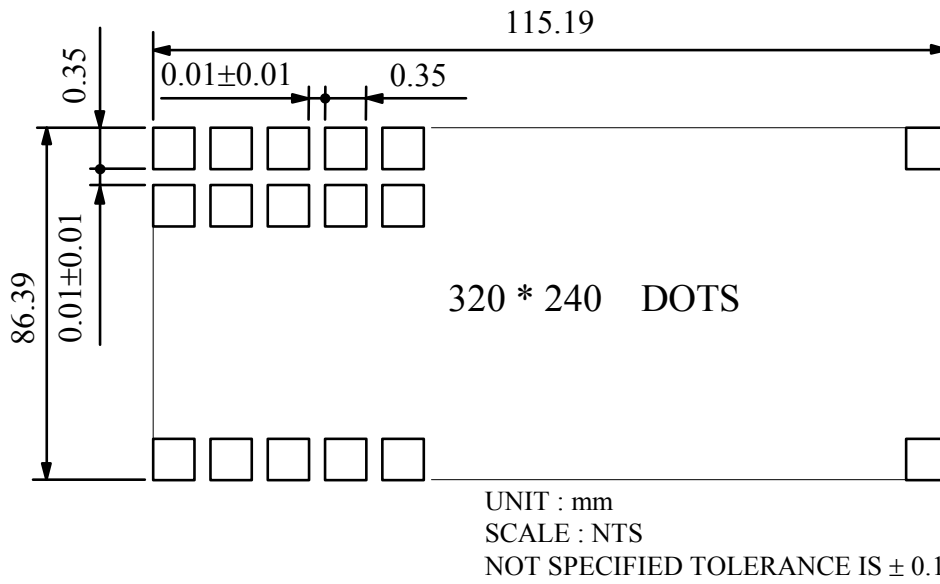

10. INTERFACE SIGNALS

IF1 :

PIN NO.	SYMBOL	LEVEL	FUNCTION
1	FLM(S)	“H”	SCAN START-UP SIGNAL
2	CL1(CP1)	“H”→”L”	INPUT DATA LATCH SIGNAL
3	CL2(CP2)	“H”→”L”	DATA INPUT CLOCK SIGNAL
4	NC	—	NOT USED
5	$\overline{\text{DISPOFF}}$	“H”DISPLAY ON , “L”DISPLAY OFF	DISPLAY CONTROL SIGNAL
6	D0	“H” (ON) , “L” (OFF)	DISPLAY DATA SIGNAL
7	D1		
8	D2		
9	D3		
10	VDD	+5V	POWER SUPPLY FOR LOGIC
11	VSS	L	GROUND
12	VEE	—	POWER SUPPLY FOR LCD DRIVE

IF2 :

PIN NO.	SYMBOL	LEVEL	FUNCTION
1	VLED	H	THE POSITIVE VOLTAGE OF LED BACKLIGHT ( A )
2	VLSS	L	THE NEGATIVE VOLTAGE OF LED BACKLIGHT ( K )

1 1. POWER SUPPLY

1 1. 1 POWER SUPPLY FOR LCM

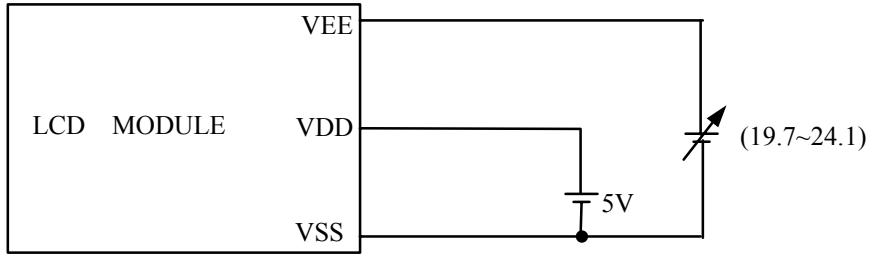

1 1. 2 POWER SUPPLY FOR LED BACK - LIGHT

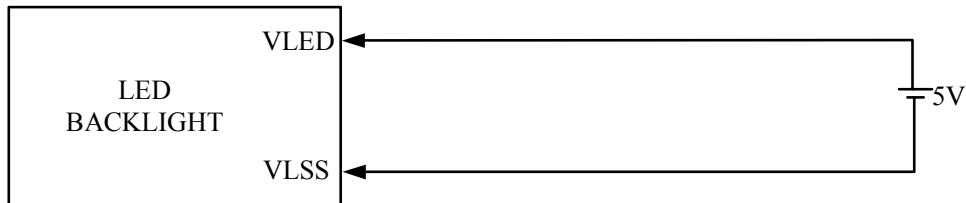

11.3 TIMING OF POWER SUPPLY AND INTERFACE SIGNAL

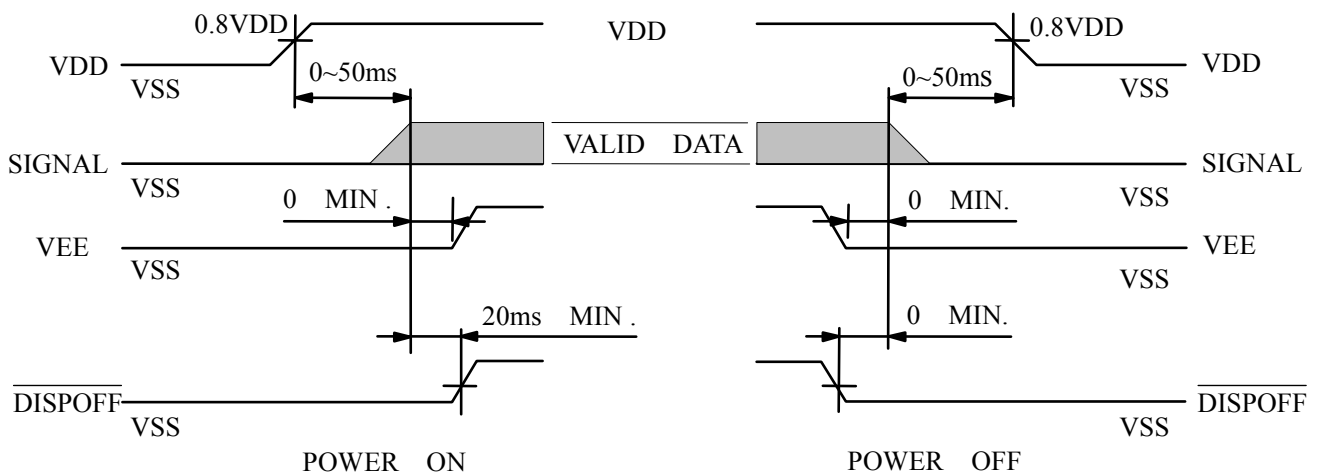

The missing pixels may occur when the LCM is driven beyond above power interface timing sequence.

12 . GENERAL RELIABILITY ASSURANCE

NO	ITEM	CONDITIONS	TIME PERIOD	REMARK
1	HIGH TEMPERATURE STORAGE	80±2°C	240HRS	2HR LEAVING ALONE AT NORMAL TEMP
2	LOW TEMPERATURE STORAGE	-30±2°C	240HRS	AS SAME AS (1)
3	HIGH TEMPERATURE HUMIDITY OPERATION	50±2°C 90% RH	240 HRS	AS SAME AS (1)
4	HIGH TEMPERATURE OPERATION	70±2°C	240 HRS	AS SAME AS (1)
5	LOW TEMPERATURE OPERATION	-20±2°C	240 HRS	AS SAME AS (1)
6	HIGH TEMPERATURE HUMIDITY STORAGE	60±2°C 90% RH	240 HRS	AS SAME AS (1)
7	THERMAL SHOCK	-20°C, 70°C 0.5H 0.5H	1HR / CYCLE 10 CYCLES	—
8	VIBRATION TEST	10 ~ 100 Hz 2.0 Gn, XYZ	1HR / EACH 3HRS	—
9	ESD TEST	AIR ± 12KV CONTACT ± 8KV	—	—
10	SHOCK TEST	50 Gn, 10ms X, Y, Z	1 TIME/EACH 3 TIMES	—